

LABORATORY MANUAL FOR VOLTMETER RESISTANCE

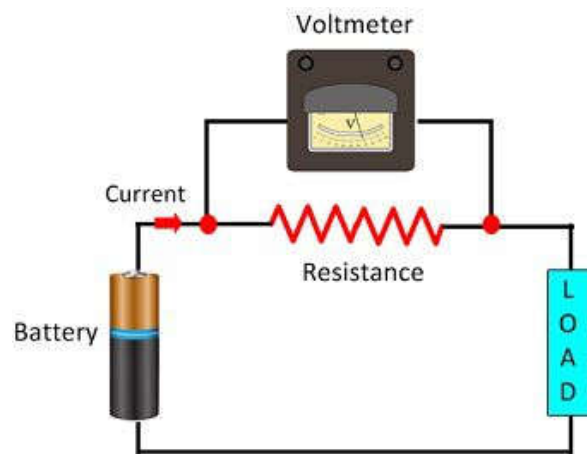

Background: Concept of Loading Effect, Concept of Voltage division, Sensitivity of Voltmeter, Voltmeter Resistance.

Experiment: To study the effect of voltmeter resistance on voltage measurement.

Apparatus: A Power source, two resistance boxes, a voltmeter, one-way key.

Theory: Ideally the resistance of a voltmeter should be infinite so that it does not alter circuit current. A low resistance voltmeter can only give correct reading if it is measuring voltage in case of a comparatively very low resistance circuit. The voltmeter produces unreliable and erroneous reading when connected to a circuit whose resistance is comparable to the resistance of the circuit. This is because when resistance of voltmeter is less than or equal to the resistance of the circuit, then voltmeter will act as a shunt path for the current & therefore the voltage drop across the resistor where we want to measure the voltage will be less.

Because of this the voltage drop will be lower than the actual value/true value (value of resistance by theory or value of resistance before voltmeter is connected). This effect is known as loading effect.

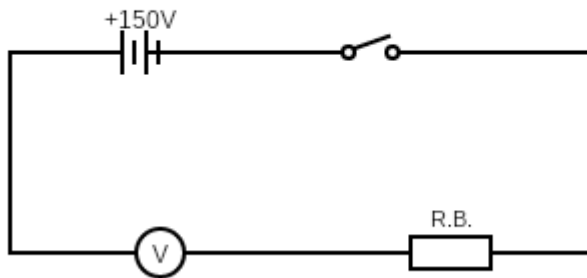

Figure 1

Let us take an example to better understand the Loading effect. Consider the figure below:-

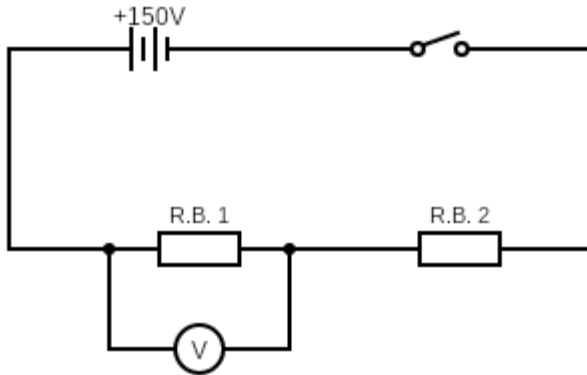

Figure 2

To understand the concept clearly let us take Resistance 50 K Ω from first resistance box and 150 K Ω from second resistance box.

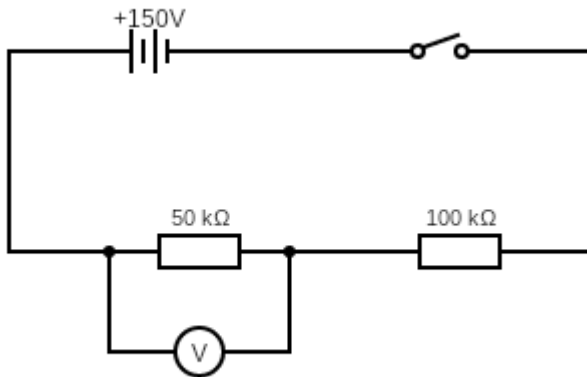

Figure 3

It is desired to measure the voltage across the 50 K Ω resistor using two Voltmeters A and B one by one. Voltmeter A has a sensitivity of 1000 Ω/V while Voltmeter B has a sensitivity of 20,000 Ω/V . The operating range of both voltmeters is in between 0-50 V.

By theory, the voltage drop across 50 K Ω resistor is given by Voltage Divider Rule

$$V_{r1} = [R_1/(R_1+R_2)]V_{Total}$$

$$V_{50K\Omega} = [50/(50+100)]150 = 50 \text{ Volt}$$

We will call this value as True Value.

Case1- When Voltmeter A is used:

Again consider Fig.3 where V is replaced with V_A

Sensitivity of Voltmeter A = $1000 \Omega/V$

Therefore, Resistance of Voltmeter $R_{vA} = \text{Sensitivity} * \text{Voltage} = 1000 * 50 = 50 \text{ K}\Omega$

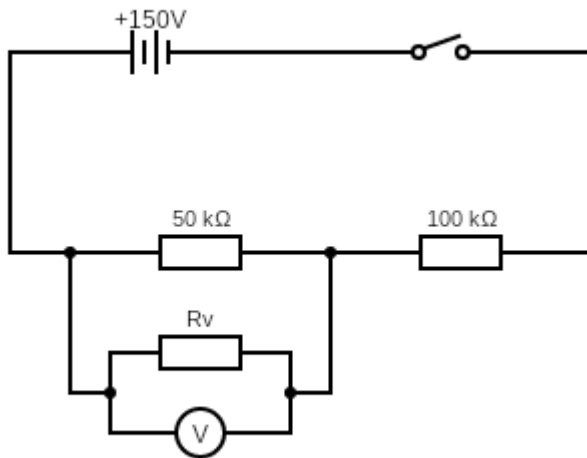

Figure 4

The effective resistance of the parallel combination is $R_{eff} = 50 * 50 / (50 + 50) = 25 \text{ K}\Omega$

[Using formula, $1/R_{eff} = 1/R_1 + 1/R_2$, where R_1 and R_2 are resistances which are connected in parallel]

Hence, the voltage drop across the resistor = $[25 / (25 + 100)] * 150 = 30 \text{ V}$ (Using Voltage divider rule)

Therefore, we see that Voltmeter A reads much smaller value than the true value.

Case2- When Voltmeter B is used:

Again consider Fig.3 where V is replaced with V_B

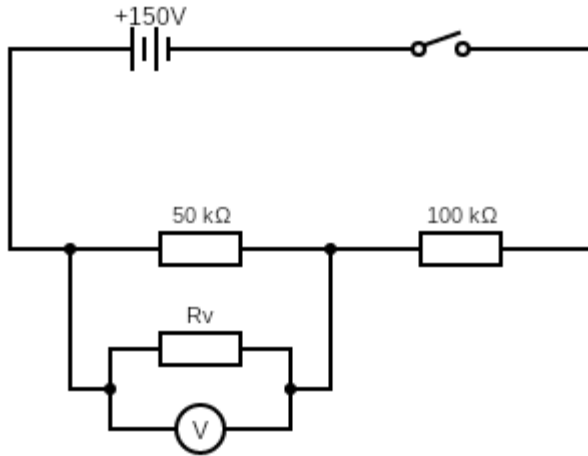

Figure 5

Sensitivity of Voltmeter $B = 20,000 \Omega/V$

Therefore, Resistance of Voltmeter $R_{vB} = \text{Sensitivity} \times \text{Voltage} = 20,000 \times 50 = 1000 \text{ K}\Omega$

The effective resistance of the parallel combination is $R_{\text{eff}} = 1000 \times 50 / (1000 + 50) = 47.6 \text{ K}\Omega$

Hence, the voltage drop across the resistor = $[47.6 / (47.6 + 100)] 150 = 48.37 \text{ V}$ (Using Voltage divider rule)

In the first case, both are comparable hence we get large deviation from True Value.

In the second case, the observed value is very close to the true value of the Voltage drop. The loading effect is not so prominent. So, we can conclude that, for getting good accuracy

The Resistance of Voltmeter $\gg \gg \gg$ Circuit Resistance

It should be noted that voltmeter with high sensitivity gives more reliable results. This is particularly true when voltage measurement is done in higher resistance circuit.

Procedure: The procedure for this experiment involves two steps:

A) Determination of voltmeter resistance (R_v)

- 1) Make connections as shown in fig. 1.
- 2) Insert all the metal plugs of the resistance box tightly (i.e. $R = 0 \text{ Ohm}$) and note the deflection in the voltmeter. Let it be θ .
- 3) Take out the metal plugs from the resistance box in small steps, so that the deflection in the voltmeter is half of the value noted in step 2 (i.e. $\theta/2$)
- 4) The value of voltmeter resistance in the resistance box (R) is voltmeter resistance R_v

B) Measurement of potential drop across a resistance

- 1) Make connections as shown in fig. 2.
- 2) Always keep the resistance R_1 and R_2 equal.
- 3) Take out metal plugs from the resistance boxes (R_1 and R_2) in steps as mentioned in the observation table. Ensure that R_1 and R_2 are equal. Note the voltmeter (V) reading. This is the observed potential drop (V) across R_1 .
- 4) Disconnect the circuit and measure the EMF (V_0) of battery used by connecting the voltmeter across the battery terminals.
- 5) The expected potential drop across R_1 is given by $V_1 = V_0/2$
- 6) Calculate the ratio of observed potential drop (V) to the expected potential drop (V_1) for each reading. Accordingly, also calculate $\log(R/R_v)$.
- 7) Plot V/V_1 versus (R/R_v) .

Observations:

(1) $V_0 =$ ___ Volts

(2) $V_1 =$ ___ Volts

(3) $R_v =$ ___ Ohms

$R_1 = R_2 = R$ Resistance (Ohms)	V Observed Potential Drop (Volt)	V/V_1	R/R_v	$\log(R/R_v)$
10				
50				
100				
200				
500				
1000				
2000				
5000				
8000				
10000				

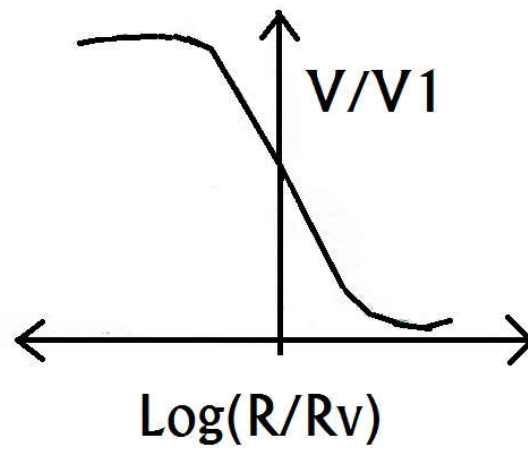

Sample viva voce Questions

1. What is loading effect?
2. What do you understand by sensitivity of Voltmeter?
3. What is Voltage Divider Rule?
4. How accuracy in resistance measurement by Voltmeter is related to its Sensitivity?